



Southern Ontario Glider Group Inc.

Club Flying Field Guidelines

NOTE: This document may be superseded by later revisions. A link on the Safety page of SOGGI's website (www.soggi.ca) will take you to the current version that is in effect at our flying sites.

Table of Contents

Revision Summary: 3

1. Definitions 5

2. Preamble..... 6

3. Applicability of the SOGGI Club Flying Field Guidelines 7

4. Revisions to and Publishing of, the SOGGI Club Flying Field Guidelines 8

5. Proof of Liability Insurance Coverage..... 8

6. Attaining and Retaining Model Aircraft “Pilot” Status 9

7. Hosting Guest Flyers..... 9

8. Requirements to Inform NAV Canada or Hamilton Conservation Authority Each Flying Day and “SEE and AVOID” Full-Scale Aircraft Traffic 10

9. Safety Enforcement Procedures..... 11

10. Model types permitted at SOGGI Flying Sites 12

11. Safe Field Practices 13

12. SOGGI Field Etiquette 22

Appendix A: SOGGI Safety Related Policy 24

A-1 Safety Related Duties of the SOGGI Club Executive..... 24

A-2 Safety-Related Duties of Contest Directors (CDs)..... 24

A-3 Safety-related Duties of Flight Instructors..... 25

Appendix B: Schematics of SOGGI Flying Fields 26

B-1 Schematic for Westover Slope (Hamilton Conservation Authority) 27

B-2 Schematic for #703 Highway 6 Caledonia Flying Site..... 28

Appendix C: Contest Director Briefing Notes and Checklist..... 29

C-1 Contest Director's Introduction 29

C-2 Safety Briefing 29

C-3 Specific Contest Briefing..... 31

Appendix D: Procedures after an Incident 33

Revision Summary:

Revision date 10 February 2008:

- Initial issue

Revision date 20 April 20 2008:

- Revision Control Notes added pg. 2
- Appendix B-3 Chippewa Rd (at Nebo Rd) revised

Revision date 22 January 2009:

- SOGGI Safety Guidelines updates: Table of Contents, Section 2, Section 12 and Appendix A
- SOGGI revisions reflect MAAC Safety Code revisions of Effective Date 30 September 2008

Revision date 20 January 2010:

- Recognizes the 2009 “10 Point” General MAAC Safety Code and all existing MAAC “ Specific Rules” that apply to aircraft Special Interest Categories flown at SOGGI.
- Safety instructions that were deleted from the previous MAAC Safety Code but not replaced by MAAC with “ Specific Rules” are now replaced with SOGGI Field Safety Guidelines (Section 15) instead.
- “Acting Safety Officer” is now described more directly as “any pilot present on the field”
- Various wording changes and paragraph rearrangements have been made to improve readability.
- Corresponding changes were made to the Table of Contents, page numbering, etc.

Revision date 10 April 2010:

- Added Section 15.6 addressing HLGs and DLGs

Revision date 25 February 2011:

- Deleted Schoutens site

Revision date 23 April 2012:

- On Pg. 14 crossed out the Fletcher Rd. site as it is being re-sodded in 2012.
- On Pg. 16, Appendix A-4, Westover Slope, clarified types of models to be flown there. The geological name Westover Drumlin added.
- On Pg. 17 added Appendix A-5 showing Trinity Church Rd site.

Revision Date: 15 March, 2015

Title changed to “SOGGI Club Flying Field Guidelines”

Updated to reflect current MAAC Safety and related documents

Section 12: Changes to Model Types Permitted

Section 15: Changes to SOGGI Field Safety

Appendix A: Fletcher Rd. flying site graphic removed as site no longer available.

Revised field graphics for all available flying sites:

GPS co-ordinates for field entrance added. (if Emergency Services required)

Emergency Access Code for Chippewa/Trinity Church Road added.

Southern Ontario Glider Group Inc. Club Flying Field Guidelines

Revision Date: 25 April 2016

Definitions added for AGL, BEC, ESC, Flying Privileges, Free Flight, No-Fly Zone, R/C, Sailplane, Tow Plane

Document restructured; policy related sections (previous sections 5, 8, 9) moved to Appendix A

Revisions in sections 2 to 11

Figures 1, 2 and 3 added

Flying sites moved to Appendix B

Flying sites Nebo Rd/Chippewa Rd, Trinity Church Rd/Chippewa Rd removed

Flying site #703 Hwy 6 added

Appendix C added

Revision date: 8 May 2017

Revisions in sections 7.1, 7.2 (added), 7.4 (added), 10.3.6, 10.3.7, Figure 2 and Appendix B-1, B-2

Revision date: April 9, 2018

Definition added for Altis

Preamble section 2 added

Section 9, exception added in using a drone to assist with recovery of lost models

Revisions in sections; 3.6, 8.1, 8.2, 11, 11.1.4, 11.1.6, 11.2.2, 11.2.5, 11.3.5, 11.3.6, 12.12, C-3.2

Appendix D, Procedures after an Incident added

Revisions are highlighted in yellow in the document text.

1. Definitions

In the present document, the *terms*:

"AGL Above Ground Level" AGL following a numeric altitude number means the altitude is measured from the local ground level.

"Altis" (e.g. Altis V4+) is a multi-functional electronic device designed to record altitude of R/C electric powered sailplanes with additional competition functionality.

"BEC (Battery Eliminator Circuit)" is an electronic device installed in a model aircraft for delivering electrical power from the propulsion system's battery, to the radio control system, thereby eliminating a separate battery for radio control. A BEC is typically a combined part of an ESC.

"CAM (Competition Altimeter for Models)" is an electronic device that cuts an electric sailplane throttle at a specifically set altitude or time from start of launch, whichever occurs first.

"Effective Date" shown at the bottom of each page of the Club Flying Field Guidelines means the date from which point onwards that revision of the Guidelines will govern SOGGI field operations.

"Electric" model or sailplane means the aircraft has an electric-motor propulsion system

"ESC (Electronic Speed Control)" is an electronic device installed in a model aircraft to control the rotational speed, direction and braking of an electric motor.

"Executive" or *"SOGGI Executive"* means the current elected officers of SOGGI

"Field(s)" or *"flying field(s)"* or *"flying site(s)"* means site(s) as described in Appendix B used and administered by SOGGI for the purpose of flying model aircraft.

"Flight Instructor" means a SOGGI member who is on record as being qualified to teach the safe operation of radio controlled model aircraft.

"Flying Privileges" means the privilege, recorded in SOGGI records and granted to a SOGGI member to fly radio controlled models at SOGGI flying sites. The privilege to fly may be conditional on performing a check flight as mandated by an instructor, flying only while accompanied by an instructor, flying only when accompanied by a spotter, or other conditions that the Chief Flying Instructor may stipulate.

"Free Flight" model aircraft are models which are adjusted before each flight, but not controlled during the flight.

"Guest" means persons present on the flying field for the purpose of flying who are not current SOGGI members, including any former SOGGI members who do not possess a current membership.

"Guidelines" means the SOGGI Club Flying Field Guidelines (i.e. this document).

“*his*” means his or her, as appropriate.

“*Landplane*” is a model aircraft that takes off and lands on wheels from a defined runway.

“*MAAC*” means the Model Aeronautics Association of Canada.

“*MSD*” means MAAC Safety Document(s) at its’ revision level as of the effective date of the SOGGI Club Flying Field Guidelines.

“*MPPD*” means MAAC Policy and Procedures Document(s) at its’ revision level as of the effective date of the SOGGI Club Flying Field Guidelines.

“*MAAC Documents*” means MSD’s and MPPD’s collectively.

“*No-Fly Zone*” refers to a 3 dimensional volume of airspace where flying may be unsafe or hazardous (but not limited) to; persons, animals, property or other features on the ground.

“*Pilot*” means any member who is recorded in SOGGI’s records as having met SOGGI’s criteria for unassisted and safe operation of R/C models, or Guests who have demonstrated equivalent Pilot qualifications. Pilot qualification is not applicable to the operation of free-flight models.

“*Pop-Off*” is a term used to describe when a line launched sailplane comes off the line prematurely, well before desired launching height is reached.

“*R/C*” means Radio Controlled.

“*Sailplane*” is a model aircraft designed to take advantage of rising air from thermals or slope lift to increase the duration of flight, typically radio controlled.

“*SOGGI*” means the Southern Ontario Glider Group Inc.

“*SOGGI member(s)*” or “*member(s)*” means person(s) who are current members-in-good-standing of SOGGI.

“*Tow Plane*” is a model aircraft which is used to tow into the air a non-powered model aircraft.

2. Preamble

BEFORE YOU FLY WITH SOGGI, please know that flying sites are difficult to obtain, and even harder to keep. The continued use of our existing flying sites depends upon maintaining good relationships with all stakeholders. Stakeholders include Hamilton Air Traffic Control, the “full-scale” pilots and their passengers who fly overhead, the Hamilton Conservation Authority for the Westover slope site, the owner of our sod-farm flying site, the sod-farm operating company and their employees and contractors, and the surrounding residential neighbours. The SOGGI Flying Field

Guidelines outline how Membership behaviour affects these delicate relationships. Thank you for doing your part to keep our Stakeholders happy.

BY JOINING OUR CLUB, YOU ARE ENTERING INTO A RECIPROCAL AGREEMENT whereby each person's safety depends on correct and predictable behaviour by all of the fliers who are active on the flying field. We ask that all Members read the Flying Field Guidelines carefully, and adhere to them as-written. For safety reasons and to keep peace in the club, please don't improvise "alternative guidelines" or encourage others to do so. If you have questions about a particular Guideline, any member of SOGGI's Executive will be happy to provide further explanation and/or a demonstration at the field.

IF YOU FEEL THAT CHANGES TO THE GUIDELINES ARE NECESSARY, contact the SOGGI Executive. Input from Members will be considered and prioritized. The Executive team updates the Guidelines at least annually. The Guidelines summarize best-practices for R/C Soaring, drawing on several decades of our own club's experience, as well as the experience of the wider R/C Soaring Community. In addition to informing the Membership concerning best practices, the Guidelines provide the SOGGI Executive team with a standard reference point to be used when arbitrating disputes or complaints involving SOGGI Members.

3. Applicability of the SOGGI Club Flying Field Guidelines

- 3.1 As a condition of SOGGI membership, members must be familiar with and adhere to the SOGGI Guidelines, and to applicable sections of the MAAC Safety Code and MAAC Policies and Procedures Documents.
- 3.2 No member shall undermine the implementation of these Guidelines by misrepresenting what the Guidelines actually say, by disputing the applicability of the Guidelines, or by encouraging others to break the Guidelines.
- 3.3 While on the flying field, any member who has met SOGGI's qualifications to be a model aircraft "Pilot" is both authorized, and obligated to enforce the Guidelines. This forms SOGGI's frontline enforcement policy for field safety.
- 3.4 No Pilot has the right to refuse, delay, or ignore his safety enforcement duties, nor can these duties be transferred to another person.
- 3.5 All SOGGI members and their guests must follow the guidelines in sections 5. through 12. SOGGI members who have specific roles in the Club Executive, as a Contest Director or as a Flight Instructor have the additional safety related policy responsibilities outlined in Appendix A.
- 3.6 Persons who are not members of SOGGI (e.g. spectators, dog walkers, agents of the landowner etc.) entering a SOGGI flying site may be unaware of hazards posed by model aircraft activity in progress. SOGGI Members are to approach them to indicate the nature and locations of these hazards, and determine whether non-SOGGI members presence constitutes a safety hazard. All

model flying is to cease until the presence of non-SOGGI members satisfies the Flying Field Guidelines.

4. Revisions to and Publishing of, the SOGGI Club Flying Field Guidelines

- 4.1 Motion(s) advocating specific revision(s) to the SOGGI Guidelines may be made at any Membership Meeting, by any SOGGI member. Proposed revision(s) may then be adopted by vote of the SOGGI membership.
- 4.2 SOGGI has adopted applicable sections of the MAAC Safety Code and the MAAC Policy and Procedure Documents, at their revision levels existing on the effective date of these SOGGI Flying Field Guidelines. SOGGI's adoption of subsequent revisions of MAAC documents will be subject to a time period allowing for adequate review, and for notification of SOGGI's membership. SOGGI members are cautioned that any duplication between the SOGGI Guidelines and MAAC Safety Code is minimal. Therefore knowledge of both the SOGGI Guidelines and the MAAC documents will be required in daily practice.
- 4.3 SOGGI's Guidelines and the MAAC Documents are all subject to periodic revision. It is each Member's own responsibility to maintain current knowledge of relevant documents. Any revision of the SOGGI Guidelines will be noted in the SOGGI Membership Meeting Minutes. Minutes are published in "TASK" (SOGGI's newsletter) which is distributed to the entire membership. This is deemed to be official notification from the Club to its members, that a revision to the Guidelines has been made.
- 4.4 The version of the SOGGI Guidelines in current effect will be made continuously available on the club's website, www.soggi.ca. MAAC documents related to these Guidelines can be found on the MAAC website www.maac.ca.
Using these files, any person can obtain hardcopies of documents through public libraries that offer Internet and printing services.

5. Proof of Liability Insurance Coverage

- 5.1 Membership in MAAC provides liability insurance coverage to MAAC Members. When flying or learning to fly at SOGGI flying sites, SOGGI Members must carry valid SOGGI and MAAC membership cards. Canadian guests who wish to fly at SOGGI must carry a valid MAAC membership card. American guests who wish to fly at SOGGI sites must carry a valid Academy of Model Aeronautics (AMA) membership card which confers similar insurance coverage.
- 5.2 To fly at SOGGI, the above Membership cards must be displayed on demand.

6. Attaining and Retaining Model Aircraft “Pilot” Status

6.1 Only a SOGGI Flight Instructor can award flying privileges to new SOGGI members. Prior to flying at SOGGI flying sites, anyone seeking membership must contact a SOGGI Flight Instructor who will ascertain their qualifications for Pilot status. Our Flight Instructors’ contact-information can be found on SOGGI’s Membership List, and on SOGGI’s website, www.soggi.ca

6.2 Regardless of experience level, the general criteria that must be met to attain and retain Pilot status includes:

- The ability to determine that a model aircraft and related equipment are airworthy.
- Demonstration of safe, disciplined, and confident flying skills appropriate to the type of model being flown.
- Displaying familiarity and compliance with the SOGGI Guidelines including applicable sections of the MAAC Safety Documents and MAAC Policy and Procedure Documents.
- Having enough knowledge and confidence to enforce the SOGGI Guidelines and MAAC Safety documents, since all accredited pilots are required to do so.

6.3 Before flying solo at SOGGI flying sites, Members who are new to SOGGI but have held “Pilot” accreditation at other clubs, are nevertheless responsible for passing a satisfactory check-out flight with a SOGGI Flight Instructor. A Pilot History Record form documenting their pilot training and/or equivalent experience must also be completed.

7. Hosting Guest Flyers

7.1 Members of the public may be invited to fly at SOGGI by SOGGI Members, provided that all of the following conditions are met:

- The Guest must be hosted by a named-SOGGI-Member who holds SOGGI “Pilot” status and SOGGI flying privileges.
- The Guest must show proof that he is a current MAAC or AMA member in good standing.
- The Guest must have successfully completed the MAAC Level “A” training program or a recognized equivalent
- The Guest must know, and abide by relevant sections of the MAAC Safety Code and the SOGGI Flying Field Guidelines.
- The Host must be present on the field at all times when his guest is flying.

7.2 If all of the foregoing conditions are not satisfied, then alternatively the Guest can be hosted by a SOGGI Flight Instructor provided that arrangements are made in advance. Otherwise Guests are not permitted to fly at SOGGI.

8. Requirements to Inform NAV Canada or Hamilton Conservation Authority Each Flying Day and “SEE and AVOID” Full-Scale Aircraft Traffic

8.1 Informing NAV Canada for the Hwy #6 Sod Farm Field

This sod farm flying site is within the John C. Munro Hamilton International Airport Control Zone. On any given day, if you are the first SOGGI Member to arrive at the field, **YOU MUST phone NAV Canada at Hamilton Airport from the field, to indicate that model flying operations are intended that day. Your phone call will request activation of a NOTAM.** The phone number, specific procedure and logbook for making the call are provided at the field where the frequency board, cones and landing tapes are stored.

If you do not have a cell phone for calling ATC from the field, then you must wait until someone with a cell phone arrives, and completes the NOTAM activation process.

TO AVOID MISUNDERSTANDINGS, DO NOT REMOVE ANY OF YOUR EQUIPMENT FROM YOUR CAR, AND DO NOT FLY UNTIL THE NOTAM HAS BEEN ACTIVATED. If you encounter other persons flying, or preparing to fly before the NOTAM has been activated, report the incident to any member of SOGGI's Executive for follow up. We will need their name(s), and/or license plate number(s), and the time and date of the incident.

This NOTAM activation procedure does not apply to the Westover slope soaring site.

8.2 Informing Hamilton Conservation Authority when using the Westover Slope

As part of the agreement with Hamilton Conservation Authority we are required to notify them when we fly at Westover. Please follow this procedure on the actual day you decide to fly at Westover.

- Check the SOGGI message board (www.soggi.ca) to see if another member has posted to say that Hamilton Conservation Authority has already been notified. If another member has already posted that HCA has been notified, you need to do no more. **Go and fly.**
- If a message board post has not been made on the day that you decide to fly at Westover, then send an email or make a phone call to the Superintendent at Valens Lake Conservation Area. The content of the email or phone call need be no more than shown in the footnote below¹. The email address and phone number can be obtained from the

¹ **From:** MEYSNER. Andy

Sent: Saturday, October 7, 2017 6:47 AM

To: Paul Karbusicky

Subject: Model Flying at Westover Today

Hi Paul, We'll be flying at Westover today. Andy Meysner, SOGGI

SOGGI President or another member of the Executive. We are not publicly disclosing this information to reduce the possibility of misuse.

- **Having contacted the HCA, immediately post a message on the SOGGI message board (www.soggi.ca) indicating** that you are flying at Westover today and that you have informed Hamilton Conservation Authority. The purpose of this post is to avoid duplicate notifications to Hamilton Conservation Authority for a given day.
- **DO NOT EMAIL OR PHONE ON AN EARLIER DAY, SINCE CHANGING WEATHER MAY RESULT IN YOU NOT GOING TO FLY ON THE DAY INTENDED.**

8.3 Flying of all types of model aircraft at the sod farm site is limited to a maximum altitude of 1200 feet (365 meters) AGL.

8.4 Flying at the Westover slope site is limited to a maximum altitude of 500 feet (305 meters) AGL of the top of the slope.

8.5 Frequent full scale traffic may fly over, or in close proximity to both SOGGI's sod farm and Westover slope flying sites. Model flying is only permitted during daylight hours, and only when models are clearly visible.

8.6 When a possible hazard due to the approach of full-scale traffic is detected, immediate and vigorous avoidance action shall be taken by the model pilot. He shall also alert any other model pilots who are flying, that a developing hazard may exist.

8.7 Other persons present on the field should ensure that all model pilots who are flying, have been alerted about any full-scale traffic that may present a hazard.

8.8 While present at the flying field, all SOGGI members are required to carry a whistle which shall be used to warn other pilots present on the field of the approach of full-scale aircraft traffic.

8.9 SOGGI members who have a medically-diagnosed hearing loss should fly with the assistance of their own designated spotter.

See also Appendix sections A-2.2 and C-2.1 for spotting procedures during contests.

9. Safety Enforcement Procedures

9.1 More than one Pilot may be on the field at a given time, and whenever possible they should act together to correct unsafe situations.

9.2 All members on the flying site must co-operate with, (and when asked) actively assist other Pilots engaged in safety enforcement duties.

9.3 If an activity in progress is deemed by any Pilot to be unsafe, or contrary to any part of the Guidelines, then pilots who are present are to ask that the activity to be stopped, at least until a

referral to the Guidelines can be made. Until all parties present are in agreement that the activity is both safe, and in agreement with the Field Guidelines, then the activity is not to be resumed that day, or on any other day.

9.4 Whenever a dispute persists as to the safety of an activity, relevant details are to be recorded, including a description of the activity, date of occurrence, and names of persons who were present on the field. Those details are to be forwarded to the Executive Committee to aid in their follow-up investigation.

9.5 Reported safety concerns will be reviewed at the next SOGGI Executive Committee Meeting. Involved parties will be invited to attend. If SOGGI's Executive Committee concludes that unsafe activity has occurred and is likely to continue, or if the person alleged to have carried out an unsafe activity fails to attend the Executive meeting in question, then that person's membership in SOGGI can be revoked by majority vote of the Executive Committee Members present. Any further activity by the offender at SOGGI flying sites will be viewed as an act of trespass.

10. Model types permitted at SOGGI Flying Sites

Note that SOGGI is primarily a "*Climb and Glide*" model Sailplane organization. Only the following model-types are permitted, and only under the conditions as follows. Refer also to Appendix B Schematics of SOGGI Flying Fields:

Permitted at Sod Farm Flying Sites:

- R/C Sailplanes launched by winch or hi-start or by any form of hand launch
- R/C Electric Sailplanes
- Free-flight (rubber-powered models or towline-launched gliders, only)

Permitted at Sod Farm Flying Sites **when other model-types are not active:**

- R/C Sailplanes launched by R/C electric powered landplanes e.g. aero-tow, or piggy back).
- Small R/C Electric Landplanes

Permitted at the Westover Slope Soaring Site

- R/C Slope Soaring sailplanes (non-powered, only)

Not Permitted at any SOGGI flying site:

- Models controlled by First-Person-View (FPV) technology
- Models controlled by way-point navigation technology
- Internal combustion engine powered models
- Model Rockets
- Rotary wing models
 - The following exception applies for rotary wing models. A drone with a camera may be used to assist searching for a lost model, after informing a member of the

SOGGI Executive that it is planned to do so. Also see section 12.12 regarding etiquette in recovery of lost models on neighbouring property.

11. Safe Field Practices

Where there is an absence of guidance available from MAAC documents, this Section of the SOGGI Guidelines addresses the safe operation of each of the permitted model types.

Refer to Appendix B for details specific to SOGGI flying sites.

Refer to Appendix D for procedures after an incident.

11.1 Permitted R/C Model-Types at Sod Farm Flying Sites

- 11.1 Before R/C flying begins, the first R/C flyer to arrive on the field shall set up the radio frequency control board and the pit area. When R/C flying ends, the last R/C flyer to depart shall return the Frequency Board, and the Pit Area traffic cones to their designated storage locations.
 - 11.1.2 A Pit area is to be delineated using “traffic cones”. ALL R/C model-types are to be assembled, range-checked and serviced in the same pit area. See Figure 2 for layout of the pit area.
 - 11.1.3 The Frequency Board is to be placed at the entry point to the pit area, and is to be used for identifying all R/C systems present on the field, including 2.4 GHz systems. A Frequency-Pin with the Pilot’s name and frequency on it is to be placed on the Frequency Board in the space provided for his frequency.
(By placing a Frequency Pin on the board, a Pilot at a distant field location using a 2.4GHz transmitter, is indicating to arriving pilots that he is not on a 72 MHz frequency where interference could be a concern.)
 - 11.1.4 All vehicle parking areas, spectator areas, pit areas, R/C Pilot Stations, in-progress line-launch activity, landing targets, and any other areas on or near the field where people or manned-machinery are present, are “No-Fly Zones”. “No-fly” means no flying below an altitude of approximately 350 feet (107 meters) ... about the same height as a good hi-start launch. Additional site-specific “No-Fly Zones” are identified in Appendix B.
 - 11.1.5 Spectators are to be encouraged to view field-activity from the pit area, except by special invitation having the knowledge and consent of all pilots present. Any special invitation must include a safety briefing from the spectator’s SOGGI-member-host.
 - 11.1.6 Members are advised that when flying alone, extra caution is necessary. Obtaining timely emergency assistance will rely on your own ability to call for help using your cell phone.

11.2 For Line-launch Sailplanes and Electric Sailplanes at Sod Farm Flying Sites

Refer to Figure 1

- 11.2.1 Do not attempt to operate a winch or hi-start until you have received training in its use. These devices are potentially dangerous to the operator, and to others in the vicinity. Contact an Instructor for further information.
- 11.2.2 **Winches and hi-starts must be set up to produce the Standard Flight Line as detailed in Figure 1.** This basic arrangement has proven successful in countless contests over a time-span of decades. **Alternative Flight Line configurations are NOT necessary, nor are they permitted.**
- 11.2.3 **The Standard Flight Line configuration is to be established by the first line-launch pilot to arrive on the field, starting with his first flight of the day.**
- 11.2.4 Launches are to be made into the prevailing wind direction. If the prevailing wind changes significantly to crosswind or downwind, then the entire Standard Flight Line shall be re-aligned into the prevailing wind.
- 11.2.5 The specified **760 ft minimum** distance of the Standard Flight Line from the Up-Wind field boundary (or other obstruction) is based on a Standard Hi-start's stretched-length of 750 ft. plus a nominal clearance of 10 ft. to the boundary. Winch-to-turnaround distances are typically less than **760 ft.**, but nonetheless, winch placement must conform to the Standard Flight Line as shown.
- 11.2.6 Pilot stations for Hi-starts of non-standard length must nonetheless conform to the same Standard Flight Line. Hi-starts longer than the 750 ft (maximum stretched length) are not permitted, unless a shared Flight Line is pre-existing, and has proportionately greater distances than the 3 minimum separation distances shown in Figure 1.
- 11.2.7 For optimum communication and for mutual visibility, once a Standard Flight Line for Line-launched sailplanes is established, then **Electric sailplanes must conform to and launch from the same Standard Flight Line.** Electric Sailplanes are to launch in the same upwind direction, and may share the same pilot stations and landing targets with line-launched sailplanes.
- 11.2.8 Prior to launching any Sailplane, the pilot must ensure that all persons are outside of the acute hazard zone. He must then signal his intention to launch by calling out, "Launching" to any adjacent pilots.
- 11.2.9 Prior to entering a shared landing zone to retrieve a model, the retriever is to call out his intention to other pilots. After retrieving a model from the landing zone, the retriever is to exit the landing zone as quickly as is safely possible.

Figure 1

Schematic of a Standard Flightline for Line-Launch and Electric Sailplanes

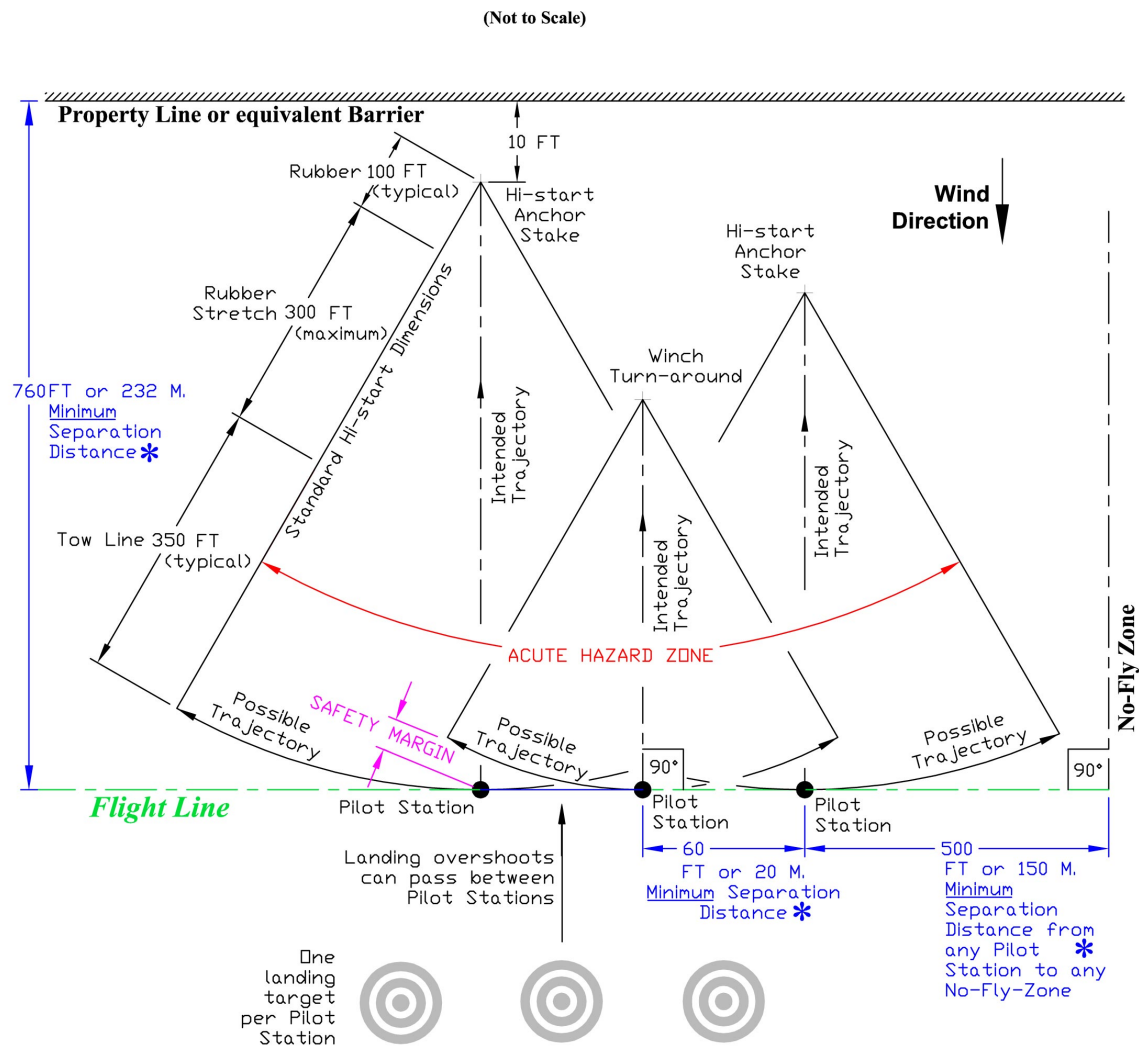

THE FIRST WINCH or HI-START SAILPLANE PILOT TO ARRIVE
is responsible for establishing a STANDARD FLIGHT LINE that:

- a) Is aligned for launching and landing into the Prevailing Wind .
- b) Satisfies the 3 Minimum separation distances *, and .
- c) Allots space for Additional Pilot Stations in case they are needed .

ALL ELECTRIC and LINE-LAUNCH PILOTS ARRIVING LATER, are to use the same flightline thus established.

Pilots **ARE NOT TO LAUNCH** while any person is within the **ACUTE HAZARD ZONE**.

To preserve **SAFETY MARGINS**, Pilots **MUST BE IN THEIR PILOT STATIONS**.

11.3 For All Types of R/C Electric Propulsion Models

- 11.3.1 Lithium Polymer (Li-Po) batteries that are commonly used for propulsion of electric models have a very high energy density. Overcharging, charging too fast, short-circuiting, and/or mechanical crash-damage can result in combustion and possibly explosion of the battery. LiPo batteries require a special type of charger. Speak with a flight instructor if you are planning to use this type of battery but are unfamiliar with the appropriate safety precautions.
- 11.3.2 SOGGI members are cautioned that inadvertent start-up of electric propulsion motors is dangerous, and occurs all-too-frequently. Rotating propeller blades can cause very serious lacerations. Fractured propeller blades make sharp projectiles. When your airborne system is energized, keep your body-parts well clear of the propeller at all times.
- 11.3.3 Never leave an energized electric model unattended. If an electric model is not held securely when the motor starts, it may become an out-of-control projectile. When being assembled, serviced, or range-checked in the pit area, electric models must always be located on the pit perimeter, with their propeller shaft pointed outward, away from people and pathways. Avoid walking in front of any electric model being serviced. See Figure 2 Pit Arrangement Concepts for Electric Propulsion Safety.
- 11.3.4 Never carry a model with the electric propulsion system energized. When carrying a model, the propulsion battery must be *physically* disconnected.
- 11.3.5 Common Mistakes that can Lead to Accidents

If power is connected to the aircraft's electronic speed control, just setting the "motor-off switch" to "OFF", or setting the "Throttle Stick" to "Zero" on the radio transmitter does **NOT** provide adequate protection against unexpected motor start-ups. In the absence of an intentional signal, some ESC's will instantaneously go to FULL THROTTLE. How do accidents happen? Here are *some* of the more common errors ...

- If you haven't yet programmed the transmitter's throttle failsafe to OFF, the motor may go to full throttle if you:
 - energize aircraft control and propulsion systems with the transmitter OFF
 - Turning OFF, accidentally or otherwise, the transmitter (or receiver) while the aircraft's ESC remains energized. Note a motor may often start up, even at zero throttle, if the transmitter is turned off before the aircraft is de-energized.
- If using ALES altitude limiting devices, you may forget that throttle-off for landing causes the motor to re-arm. The throttle stick is active.
- The above errors can combine with additional errors to cause injury:
 - Fumbling with the transmitter, may move the throttle-stick or motor-switch to high throttle (beware of transmitters swinging on a neck-strap)
 - Failure to restrain an energized model can result in a loose projectile.
 - Carrying an energized model invites injury from the propeller.

Figure 2

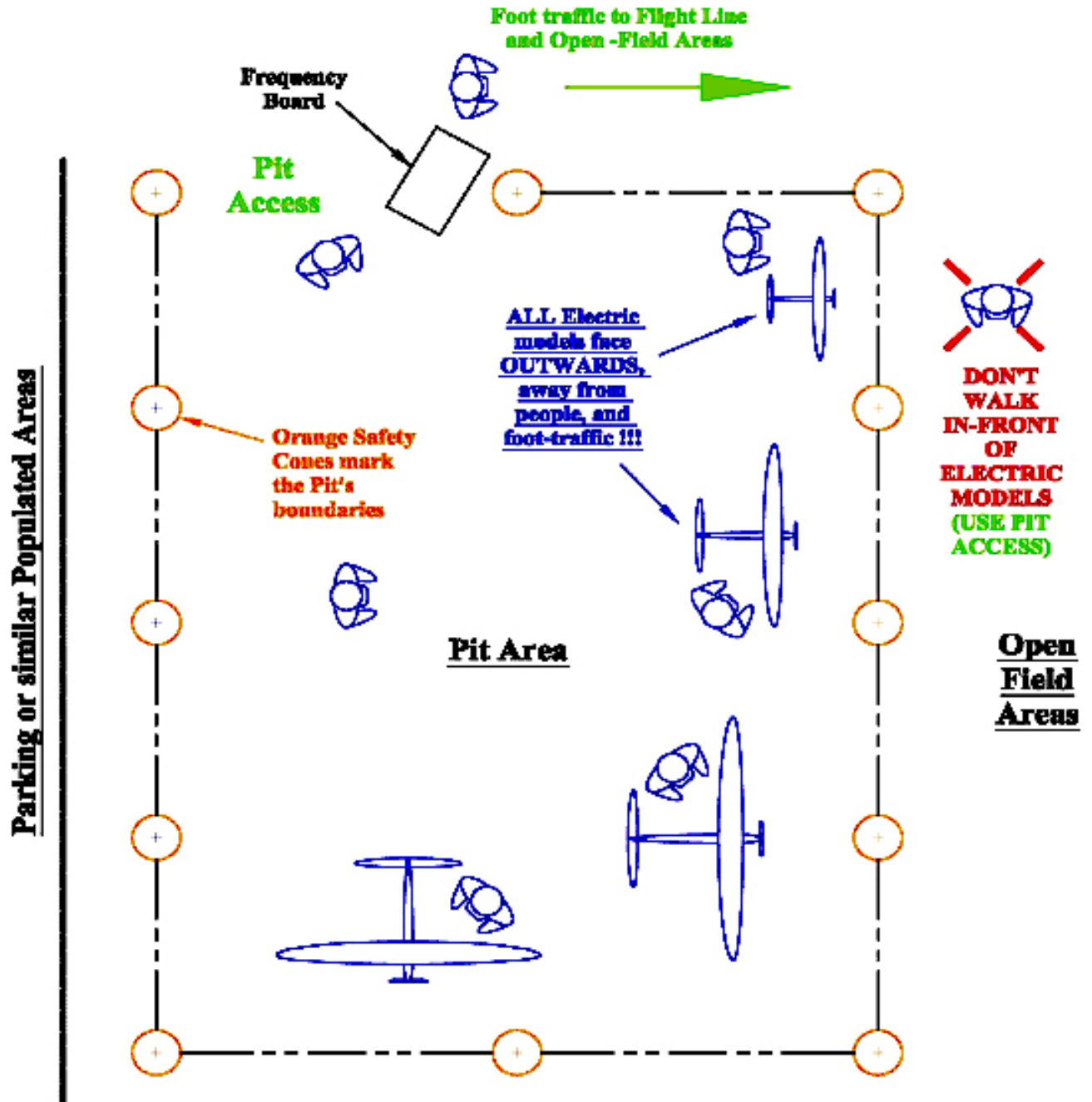

11.3.6 Performing a Radio Range Check on an Electric Propulsion Model

If the transmitter offers failsafe programming, always program Failsafe to “Throttle OFF”.

Transmitters should *ALWAYS* be switched ON and the throttle set to OFF, *BEFORE* connecting the propulsion battery **to energize the airborne system.**

Radio range checks must be performed as mandated by the MAAC Safety Code. **If range is lost during a range check, it must be assumed that the Electric Propulsion Motor can start up instantaneously at full throttle. To avoid this hazard, either propulsion must be prevented, or the model must be physically restrained while performing a range check**

For control systems powered by the Electric Speed Control’s Battery Eliminator Circuit (BEC), disconnecting the propulsion battery has the side-effect of shutting off the receiver and servos. This would then prevent execution of the radio range check, unless one of several safe work-around procedures is employed as follows:

Procedure 1 (the preferred procedure): Employ a trained-assistant, or a proper fixture to restrain the model during range checks.

Procedure 2: (See Figure 3) Perform range-checks with the propeller removed. This allows the motor (without propeller) to be test-run during the range check. If Procedure 2 is used to range check high-powered models (e.g. over 200 watts), precautions should also be taken to prevent loose clothing or hair from becoming entangled with the spinning propulsion motor shaft. To safely remove the propeller of a BEC-equipped model:

- The Propulsion Battery must be physically disconnected.
- Then the propeller can be safely removed.
- The Propulsion Battery can be then reconnected and a range check carried out following your radio manufacturer’s instructions.
- And finally, the Propulsion Battery must be disconnected again, to safely re-install the propeller.

Procedure 3: (See Figure 3) Perform range-checks with the motor disabled. This method precludes simulation of radio control function under “motor running” conditions.

To safely disconnect the ESC’s motor power cables of a BEC-equipped model:

- The Propulsion Battery must be physically disconnected.
- Then the power cables leading from the ESC to the Motor can be safely disconnected***.
- Then the Propulsion Battery can be reconnected, so that the BEC can power the aircraft’s radio control system during the range check.
- After the range check is complete, the Propulsion Battery must again be disconnected, so that the power cables from the ESC to the Motor can be safely reconnected.

*** For **BRUSHLESS** motors, erratic rotation of a brushless motor can still occur, as long as any two of the three brushless motor power conductors remain connected. Disconnect at least two of the three power conductors that connect the propulsion motor to the ESC, to prevent the motor from starting. For **BRUSHED** motors connected to an ESC, disconnection of either of the **motor's** two power conductors will prevent the motor from starting.

Procedure 4.: If the receiver is not powered by a BEC (i.e. if the airborne radio control system has its' own dedicated battery) then the propulsion-motor battery can, (and for safety reasons, must) be disconnected to permit a radio range-check to proceed. A range test using Procedure 4 therefore cannot test radio range under "motor running" conditions.

11.3.7 It is recommended that each pilot carry the manual for his Electronic Speed Control (ESC) and the manual for any Altitude Limiting Device, to aid in their re-programming on the field, should that prove necessary.

11.4 For Hand-launched R/C Gliders (HLGs) and Discus Launched Gliders (DLGs)

11.4.1 HLG and DLG pilots must establish their launch and landing zone at a safe distance from all other activities that may be present on the field. When there is an inadvertent HLG/DLG landing that impinges on the operations of line-launch and/or electric sailplanes, the HLG/DLG pilot must signal to those pilots his intention to retrieve his HLG/DLG. Retrieval is permitted only when those pilots signal that it's safe to do so.

11.4.2 The launch trajectories of DLG's are sometimes erratic. A DLG pilot must announce his/her intention to launch whenever other people are within 20 Meters of the DLG's release point.

11.5 For Free-flight Models at Sod Farm Flying Sites

The free-flight pilot is to familiarize himself with the hazards of sharing the field with R/C model operations, and insofar as possible, choose flight paths that avoid overflying R/C flight-lines. During recovery of his model, or when entering or leaving the field, the free-flight pilot is to avoid walking through the R/C flight-lines or under R/C flight paths. If entry into an R/C take-off/landing area is necessary, then the free-flight pilot is to give right-of-way to R/C operations, and clearly announce his presence prior to entering that area.

**Figure 3: Safely Range-Checking an Electric Model
(see Procedures 2 and 3 in Section 10.3.6)**

PROCEDURE 2

Disconnection makes it safe to remove propeller. Then reconnect to perform Range Check.

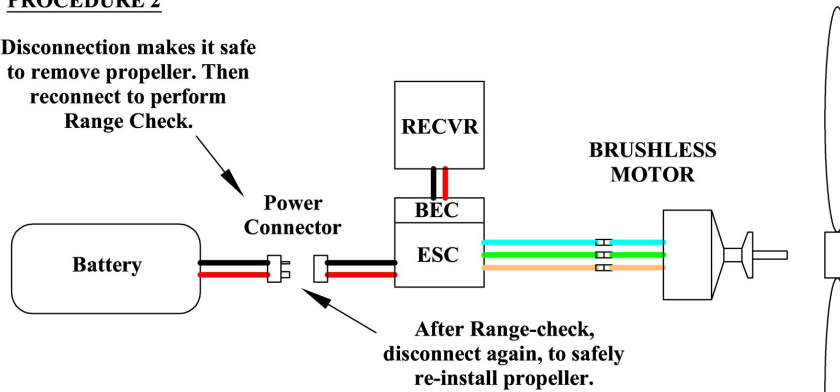

ALTERNATIVE PROCEDURE 2

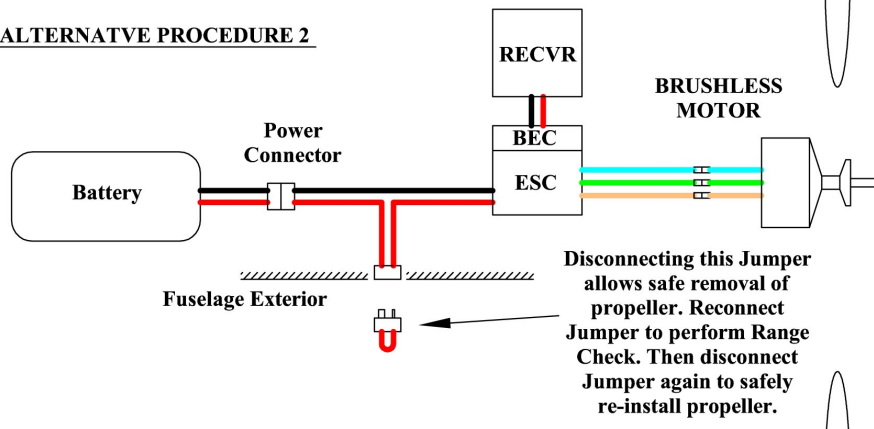

PROCEDURE 3

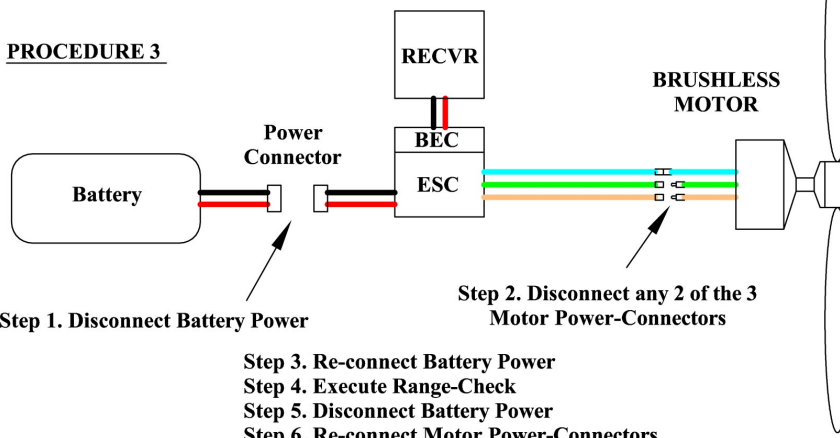

11.6 For R/C Slope Soaring at Westover Flying Site

Refer to Appendix B-1 for applicable Guidelines at Westover.

- 11.6.1 Pilots should where possible land at the top of the slope and signal their intention to other persons within a wide vicinity of the landing target.
- 11.6.2 Slope soaring pilots should be aware that, in the absence of sufficient slope or thermal lift, landing at some point further down the slope may be unavoidable. In these situations both pilots and persons retrieving models should signal their intentions to each other. The general safety and communication principles are the same as for thermal fields.
- 11.6.3 Flights made on the downwind side of the slope during strong winds, may encounter severe turbulence with consequent loss of control of the aircraft. Flying on the downwind side of the slope at low altitude is to be avoided, when people are present there.

11.7 For R/C “Landplane” Models at Sod Farm Flying Sites

- 11.7.1 There are many good clubs that specialize in landplane activity, and we recommend those clubs to anyone whose primary interest is in flying that type of model. The R/C Landplane category is incorporated in these Flying Field Guidelines for the benefit of SOGGI Climb-and-Glide enthusiasts who may have a secondary, occasional interest in flying a Landplane at our sod farm flying sites.
- 11.7.2 Landplanes must be operated from a separate area of the field, and only when a separate area of the field is available for that purpose. At all times, field-position preference must be yielded to “Climb and Glide” aircraft.
- 11.7.3 The landplane flight-line shall be at least 40 meters from the pit area, and from the spectator/car parking area.
- 11.7.4 The pilot station is to be located between the pit area and the flight-line, at least 10 meters away from the flight-line.
- 11.7.5 The first landplane pilot to arrive is responsible for:
 - Establishing a Landplane flight-line that:
yields field-positional preference to climb-and-glide activities at all times
is consistent with safety distances and no-fly zones, and
which provides for take-offs and landings into the prevailing wind direction.
 - Marking a Landplane pilot-station with at least two orange safety cones to make the Land Plane pilot station visible to Climb-and-Glide pilots

- Outlining a runway with at least 4 orange safety cones (2 at each end) positioned so as not to interfere with sailplane launch and landing activities.

- 11.7.6 Pilots of landplane models who arrive and fly subsequently, are to conform to the landplane pilot station, runway and no-fly zones thus established.
- 11.7.7 If landplane pilots must carry their model to or from the flight-line, they are to first ensure that it is safe to enter that area, and then announce their intentions to any other pilots before proceeding. As soon as their takeoff, hand launch or retrieval is accomplished, they are to return to the pilot station.
- 11.7.8 Pilots are not to taxi their aircraft into the pit area or within close proximity of people.
- 11.7.9 Pilots using the landplane flight-line are to execute landing patterns, take off turns, and flight manoeuvres so as to avoid sailplane launch trajectories, sailplane Flight Lines, and No-Fly Zones. Aircraft landing have the right of way over aircraft taking off.
- 11.7.10 The last landplane flyer to depart shall return Pilot Station Marker(s) to the storage area.

11.8 For R/C Aerotow Operations at Sod Farm Flying Sites

- 11.8.1 The pilot of either the tow-plane or the sailplane being towed, shall inform all other pilots using the field that aerotow operations are ready to take place.
- 11.8.2 Prior to operations commencing, both the tow-plane and towed-sailplane pilots shall inspect and test the towline release mechanisms on both the towing aircraft and the sailplane, to ensure reliable release.
- 11.8.3 Prior to take-off, the sailplane pilot shall communicate with other pilots regarding his intended landing target, which maybe the aerotow takeoff runway or landing zone used by winch or Hi-Start launched sailplanes.
- 11.8.4 The tow-plane shall be operated for take-off and landing in accordance with the landplane runway procedures outlined in section 11.7.
- 11.8.5 The sailplane shall be released from the tow aircraft in a manner and at an altitude that does not endanger other aircraft, persons or property.

12. SOGGI Field Etiquette

- 12.1 SOGGI will lose access to flying sites, unless good relationships are maintained with our landowners, sod business and sod maintenance personnel, and owners of all neighbouring properties. Adhering to Field Etiquette guidelines is a condition of SOGGI membership that carries the same enforcement provisions as the Safety Guidelines.

- 12.2 Be aware that SOGGI members' access to flying sites may be interrupted from time to time at the discretion of the sod farm operator or the landowner. The SOGGI executive will advise the membership when and where flying is permitted. If field availability is in doubt, contact the SOGGI executive before flying.
- 12.3 Do not litter.
- 12.4 During springtime, do not enter any sod farm flying site until the Executive has determined that soil conditions permit entry to that site.
- 12.5 Never drive automobiles on the sod, or damage the sod in any other way. Drive very slowly to avoid damaging gravel roadways and stirring up dust.
- 12.6 Park only in designated parking areas.
- 12.7 Use the toilet facilities if provided.
- 12.8 Obey site-specific advisories given in Appendix B.
- 12.9 Treat all strangers and sod farm staff with courtesy. Respect any requests or "suggestions" made by sod farm staff or neighbours, and pass this information on to other pilots and SOGGI Executive.
- 12.10 Before setting up hi-starts or winches, if any sod farm staff are present, ensure that your plan will not interfere with their work.
- 12.11 Mark hi-start ends to make them visible to sod farm equipment operators and to make them easier for you to find when you're ready to leave. Mark your field equipment with your name and phone number. Do not abandon objects on the field that could damage sod farm equipment.
- 12.12 Recovering Lost Models: If a search is required on a neighbouring residential property, introduce yourself and ask permission of the neighbour. Unless you have permission, do not enter pastures containing horses or livestock, or fields protected by an electric fence. Do not break fences, damage trees or crops. Avoid walking near farmyards and/or hazardous areas (wells and ponds for example). Be aware that any conflict with the owner of neighbouring property runs a risk of jeopardizing our agreements with the owners of the flying fields, so be considerate to the neighbours when conducting a search.
- 12.13 Do not fly in No-Fly Zones.
- 12.14 Do not create noise that could be audible to any neighbour. Excessive noise can usually be corrected by re-balancing the propeller.
- 12.15 SOGGI members are required to report to the Executive, any negative encounters with sod farm personnel or neighbours.

Appendix A: SOGGI Safety Related Policy

A-1 Safety Related Duties of the SOGGI Club Executive

The SOGGI elected executive is responsible for overseeing implementation of the SOGGI Club Flying Field Guidelines. Certain tasks may be delegated to the general members provided that safety is not adversely affected.

The Executive's responsibility is to:

- A-1.1 Lead a periodic review of the SOGGI Guidelines, revise them if necessary through consultation with SOGGI membership, have the revised Guidelines ratified by vote of membership, and notify the membership that revisions are in effect.
- A-1.2 Promote membership awareness of safety issues and awareness of the Guidelines.
- A-1.3 Maintain records that:
 - Establish that every current SOGGI member is also a current MAAC member
 - Record which members are Pilots, Flight instructors and/or Contest Directors.
- A-1.4 Pursue appropriate safety infrastructure for flying sites typically including but not limited to, field signage, frequency boards, first aid kits, and the posting of emergency contact information.
- A-1.5 Appoint qualified flight instructors to design and implement a flight instruction program.
- A-1.6 Appoint qualified Contest Directors and expedite their related MAAC approval process.
- A-1.7 Serve as liaison with neighbours, flying field owners and air traffic authorities with respect to safety issues.
- A-1.8 Conduct discipline hearings and take action in response to Safety Incident Reports.

A-2 Safety-Related Duties of Contest Directors (CDs)

- A-2.1 The general duties of a Contest Director are outlined in the MAAC Policy Manual. Every CD must meet MAAC certification requirements that begin with his submission of a MAAC Application for Contest Director to the SOGGI Secretary.
- A-2.2 Before flying begins at any given contest, the CD must also:
 - Ensure that the Host requirements for Guest Flyers are satisfied with respect to contest participants who are not SOGGI members.

- Hold a Pilots Meeting that includes a review of notable directives contained in the SOGGI Guidelines and MAAC Safety Code documents applicable to the contest's Special Interest Category.
- Conduct a safety review of field arrangements and enlist any necessary assistance to correct shortcomings.
- Ensure that spotters for full size aircraft are designated during flying operations. Persons timing flights should also be instructed to act as spotters. The use of a whistle by spotters is required to notify pilots of hazardous situations.

A-3 Safety-related Duties of Flight Instructors

- A-3.1 SOGGI Flight Instructors are the only persons who are authorized:
- to train others to fly
 - to assist guests who are unable to demonstrate that they can fly safely unassisted
 - to award SOGGI "Pilot" status (i.e. flying privileges at SOGGI flying sites).
- A-3.2 Instructors are to be appointed by the SOGGI Executive from amongst those members who are qualified pilots, and who have in the opinion of the other Instructors and the Executive, demonstrated superior flying skills, safety awareness and an aptitude for the instruction of others.
- A-3.3 The Executive in consultation with the Flying Instructors shall appoint one Instructor to serve as Chief Flying Instructor, whose duty it is to:
- Lead in the development of training programs and methods and in the acquisition of training aids
 - Maintain a central file of all club training records.
- A-3.4 As a group, SOGGI Instructors shall develop uniform methods of instruction and testing. This may include but is not limited to making any necessary adaptations to the MAAC Wings Program "A" Level applicable to the types of R/C aircraft flown by SOGGI, and the creation of any necessary training aids, forms and tests.
- A-3.5 Each Instructor shall maintain records that indicate the progress-to-date of each of his current student pilots.
- A-3.6 When a person is awarded Pilot status, the Chief Flying Instructor shall:
- Retain a copy of the person's training record for his own file
 - Provide that person with a record of his achievement, and
 - Notify the Executive.

Appendix B: Schematics of SOGGI Flying Fields

The following Schematics of Appendix B identify no-fly zones that are specific to individual SOGGI flying site. These are additional to the general no-fly zones identified in the MAAC Safety Documents and in the preceding paragraphs of the SOGGI Guidelines.

Etiquette behaviour given in section 12 and the schematics are intended to promote good relations with neighbours and landowners.

The seasonal weather-based availability of fields will be announced in SOGGI's Membership Meeting minutes and in the TASK newsletter. If in doubt as to field status, contact any member of the Executive before you go to the field.

B-1 Schematic for Westover Slope (Hamilton Conservation Authority)

Field Entrance Location: 43° 20' 13.8" N, 80° 05' 11.7" W (On the east side of Westover Road opposite the Church)

Emergency Access Code: 118 Westover Rd. RR#1 Millgrove, Ont.

The address of the nearest medical emergency facility to Westover is:

Cambridge Memorial Hospital, 700 Coronation Blvd, Cambridge, ON N1R 3G2, 519 621 2330

Advisory: Per our agreement with Hamilton Region Conservation Authority only non-motorized gliders are allowed on what is titled the Westover Drumlin. The Drumlin is for slope soaring not thermal soaring. There is no frequency control board at the site and frequency control is the responsibility of each pilot. No smoking is allowed at the site due to the danger of grass fires in dry weather. ATVs are not permitted. Notify any member of the SOGGI Executive if you observe any untoward activity on the slope by other parties.

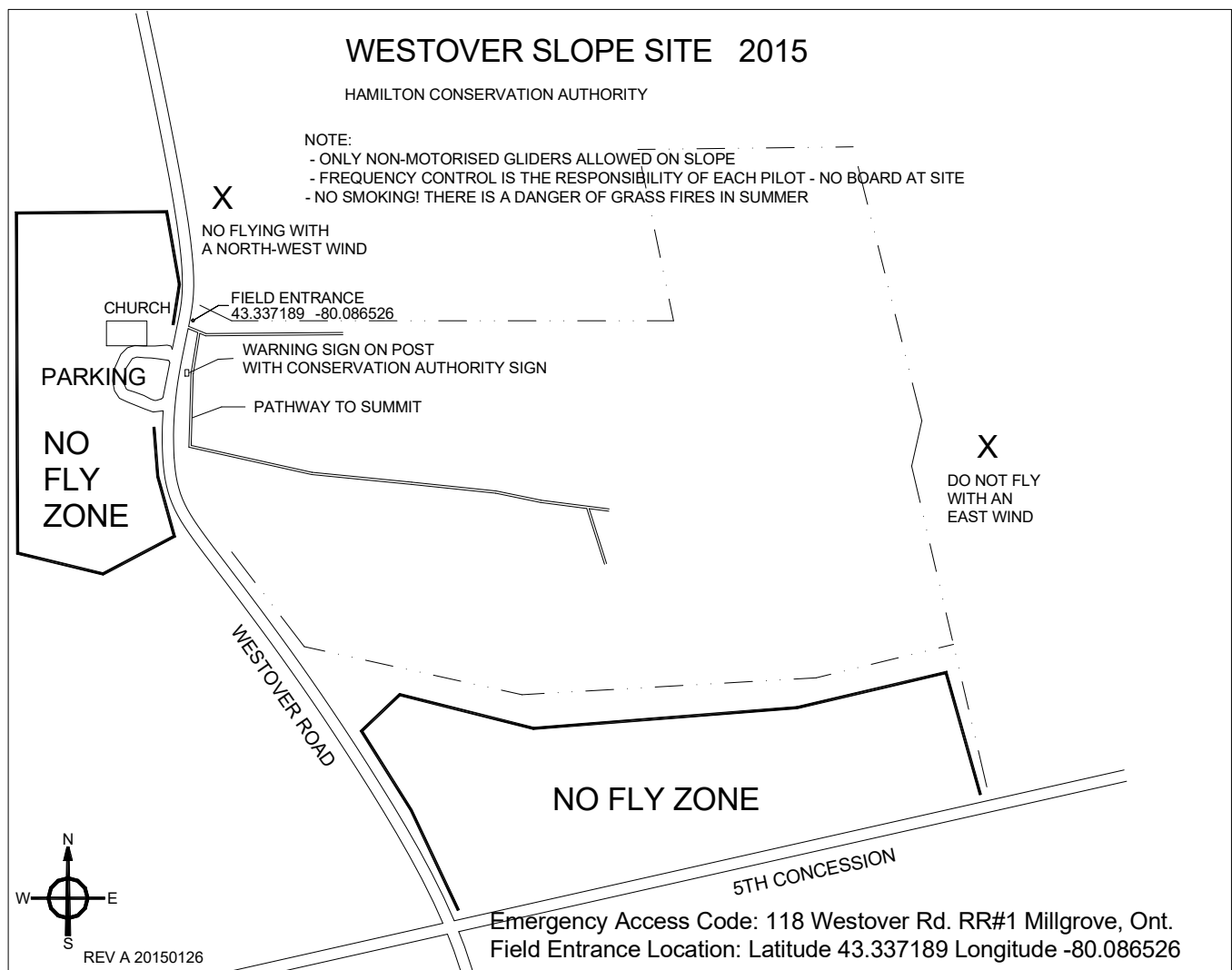

B-2 Schematic for #703 Highway 6 Caledonia Flying Site

Field Entrance Location: 43° 05' 53.7" N, 79° 56' 27.3" W. (West side of Hwy 6, 1.03 km south of Unity Road)

Emergency response to the above location.

The addresses of the nearest medical emergency facilities to this sod farm field are:

Juravinski Hospital, 711 Concession St. Hamilton ON L8V 1C1, 905 521 2100.

West Haldimand General Hospital, 75 Parkview Rd, Hagersville, ON N0A 1H0, 905 768 3311.

They are both the same distance but Juravinski may take longer due to Hamilton traffic.

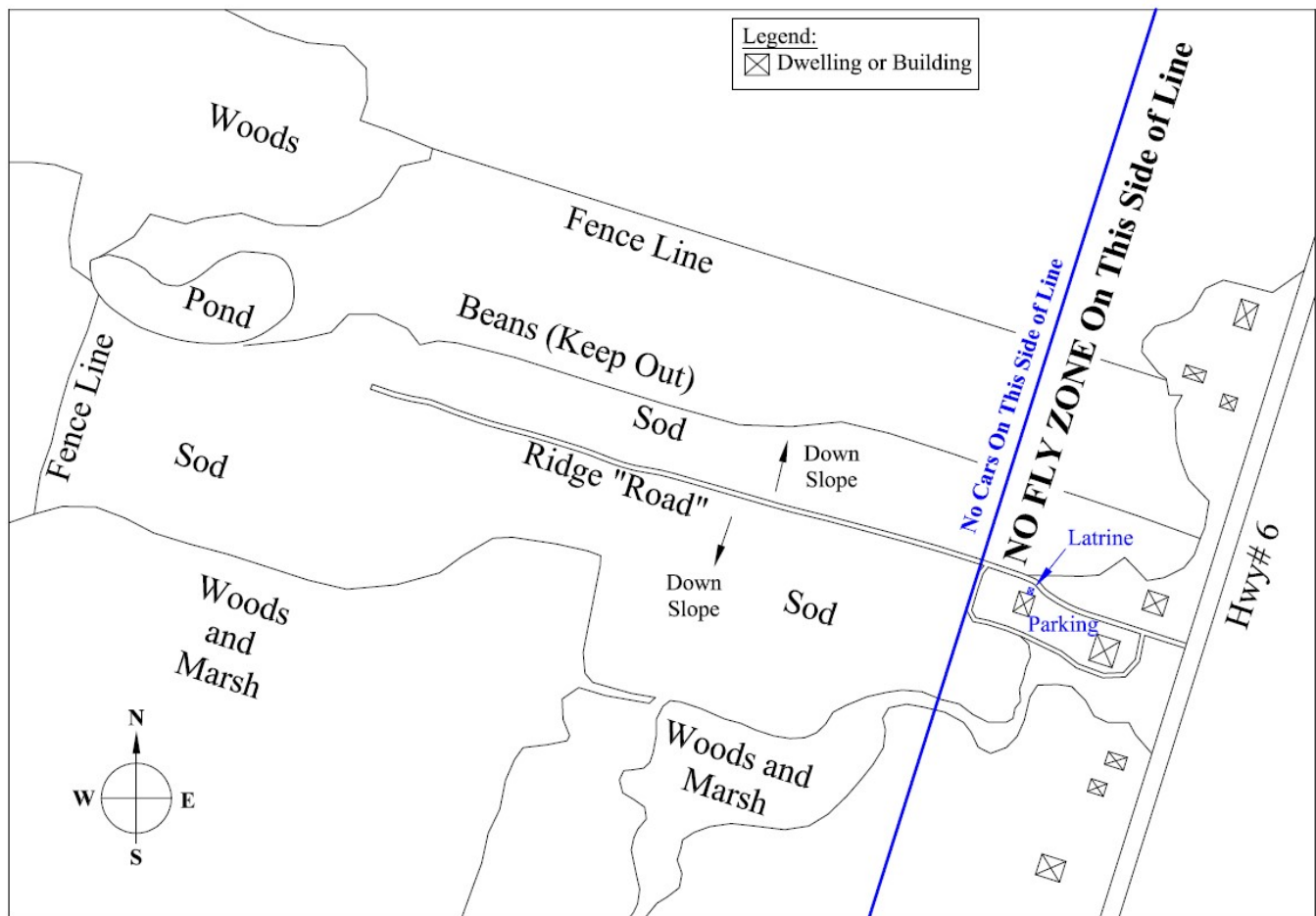

Appendix C: Contest Director Briefing Notes and Checklist

The Contest Director (CD) should request that all contestants and everyone else present attend the safety part of the briefing when it is called. Contestants, timers and helpers will need to remain at the briefing for the specific contest part of the briefing.

C-1 Contest Director's Introduction

At the start of contestants briefing:

- Introduce yourself as the CD
- Welcome all contestants, supporters and guests to the event
- Introduce what event is being held and add any personal words from you, the CD
- Point out the facilities available at the field (e.g. toilet, bottled water, shade etc.)
- Point out any other need to know information, e.g. the presence of ticks at the field
- Make it clear that safety is paramount and what will immediately follow is a safety briefing to all present, including non-contestants
- Following the safety briefing will be a briefing related to the specific contest being held today.

C-2 Safety Briefing

C-2.1 General Safety

The CD's safety briefing should cover the following:

Only contestants, timers, the CD and other necessary personnel identified by the CD are allowed on the field beyond the pit area at any time. If other personnel wish to be on the flightline (e.g. for photography or other reasons) they shall make a prior request to the CD. A safety briefing from the CD may be necessary.

Pilots are responsible to ensure that their aircraft are airworthy in accordance with MAAC and SOGGI safety policy. That includes a mandatory range check.

Electric sailplanes must face outward at the perimeter of the pit area away from pedestrian traffic (see Figure 2). Do not walk in front of electric models in the pit area. Electric sailplanes shall only be energized when range checking and immediately prior to launch. They shall be de-energized immediately after landing.

When range checking electric models, precautions shall be taken to ensure that inadvertent propeller rotation does not cause a safety hazard (see section 11.3.6).

Point out that the field is within or in close proximity to the Hamilton airport air traffic control zone. Explain the procedure for warning pilots, using a whistle, of full size aircraft in the vicinity

(see section 8). Timers are required to act as spotters, verbally warn the pilot if a full size aircraft is in the vicinity, and use a whistle to warn if a full size aircraft flight path poses a hazard.

Point out the no-fly zones specific to the field for today's contest.

If inclement weather is forecast (e.g. thunderstorms) advise procedures to be followed, i.e. must land and clear the field if lightning is observed.

C-2.2 General flight conduct:

- Avoid low (below 350 feet) flying over active roads, parking and pit areas
- Avoid low down-wind landing approaches over the flight line
- Fly clear of the active launching area
- Do not turn back into the active launch area immediately after release while launching of other sailplanes is in progress.
- If thermalling close to other sailplanes, circle in a common direction

C-2.3 Flightline Setup:

- The flightline shall be set-up in accordance with Figure 1
- The CD and designated helpers will set up the flightline
- Contestants are not to set up winches or Hi-Starts without first consulting with the CD on where to position their equipment with respect to the flightline.

C-2.4 Winch Launching:

- Warn all present that winches can cause serious harm if not used properly, not in a serviceable condition, or flightline procedures (see Figure 1) are not followed.
- Familiarize yourself with the winch you will use if it is not yours, including advice on its characteristics from the winch owner
- Ensure the winch pedal is on a firm flat surface, and comfortable to use
- Ask the Timer to assist in attaching the chute ring to the hook, and to launch the sailplane if required
- Voice "LAUNCHING" before release of the sailplane
- Request the Timer to turn the winch switch to OFF after each successful launch.

C-2.5 Hi-Start Launching:

- Pilots should ask your timer to hold and attach the tensioned chute to the hook (this is safer than the pilot holding a stretched line, then picking up the plane to attach the ring, then picking up the transmitter while the sailplane is under tension).
- Voice "LAUNCHING" before release of the sailplane

C-2.6 Retrieving Winch and Hi-Start lines:

- Retrieval of winch and Hi-Start lines shall not be carried out until all pilots on the flightline have landed their sailplanes. Typically Hi-Start lines will not be retrieved until just prior to the next round.

- C-2.7 Line breaks (Winches or Hi-Starts):
- Voice "LINE BREAK" as a warning to other launching pilots
 - Do not attempt to repair the line break until all pilots flying the round have landed their sailplanes, it is safe to do so and other personnel on the flightline have been informed of the repair work
 - Another Winch or Hi-Start may be used for the round
 - Inform the CD that a repair is necessary and agree with the CD the timing of the repair.
- C-2.8 "Pop-Offs" (Winches or Hi-Starts):
- Voice "POP-OFF" as a warning to other pilots on the flightline
 - Before retrieving the chute, wait until other pilots on the flightline have launched and it is safe to do so
 - If the chute has crossed other launching line(s) the associated winch/hi-start shall not be used until the crossed lines have been cleared
 - In the case of a winch pop-off, the launching timer shall switch off the winch until crossing lines have been cleared, before proceeding.
- C-2.9 Landings:
- Voice "LANDING" when on final approach
 - Always attempt to land upwind towards the landing tape at your pilot station
 - Voice "HEADS UP" if unable to land as above and in a manner that may endanger other personnel on the flightline. Steer between pilot stations if overshooting and do not attempt to go-around
 - If unavoidably landing some distance away from the flightline, do not retrieve your sailplane until safe to do so with respect to other pilots landing approaches, or until all pilots have landed their sailplanes in that round.

C-3 Specific Contest Briefing

- C-3.1 General Requirements
All contestants must:
- Register for the event with their MAAC card/number and transmitter frequency
 - Place a frequency pin on the frequency board, including those on 2.4 GHz
 - When called for your round promptly go out to the flightline. A delay to do this delays the entire competition. At the discretion of the CD a significant delay may result in the offending contestant forfeiting the round
 - Return your sailplane to the pit area between rounds.
- C-3.2 Specific Contest Details

This is a generic briefing checklist. The CD will need to expand upon and describe the following points depending on the CD's intent for the sailplane classes and specific contest being held etc.

- Classes of sailplane in today's contest
- Round flying durations
- Format, e.g. man-on-man, and number of pilots in each flying group
- Scoring system (e.g. using GliderScore), landing score, landing tape length, incidents that will result in a zero score etc.
- Number of rounds intended
- Signal for launch start, e.g. a whistle blast from CD/helper
- Timing clock start, e.g. at release from line for winch/Hi-Start, and at release from hand for electric sailplanes
- Timing clock end, i.e. at first point of contact with the ground
- CAM or Altis settings for electric sailplanes, e.g. 200m/30 seconds
- Any allowance/procedure for electric sailplanes without competition devices such as a CAM or Altis
- Rules for losing parts, upside down on landing or landing off field
- Allowances for pop-offs and what constitutes a pop-off
- Inform contestants of the weather expected during the day

Appendix D: Procedures after an Incident

The MAAC procedure below for reporting an incident is provided on the card that is issued to every MAAC member with their annual membership card.

If a member of the SOGGI Executive is not present at the field when the incident occurs, it is essential that one of the members present take the responsibility to inform a member of the Executive as soon as practically possible.

Procedure (https://www.maac.ca/en/.../procedures_after_an_incident_93009.pdf):

- Please do not discuss or admit to responsibility as this could compromise our position

- Arrange for **medical attention** immediately if required.

- Trainer or club executive member on site, if available, to **take control of incident** (*This will be the contact person for the Adjuster, and that individual will be responsible for the gathering of information*)

- If few people are present and no club executive, attempt to make contact. Remind them to bring a camera and paper and pen if needed as well as an Incident Report form if there are none at the field, to assist in obtaining the necessary information.

- If an INJURY is involved and it is after MAAC office hours (Mon – Fri 8:00am – 4:30pm EST), our Crawford & Co. adjusters are to be notified immediately and directly by calling their 24/7 Claims Alert number at 1-888-224-5677. Do not use this number if there is just property damage or if a member has injured himself only.

- Notify the Zone Director of the incident.

- Take **photographs** of where the incident happened, as the scene existed at the time of the incident, and/or of the property damage/injury caused.

- **Remove any potential hazards** from the scene, *after being photographed*, to prevent further incidents. All components of the aircraft that caused the damage and the transmitter must be kept for the adjusters inspection, do not throw away or attempt to repair parts.

- Obtain information on injured party, or party who sustained the property damage – i.e.

- Name

- Address

- Phone # and or Person to contact

- Their version of what happened.

- An executive of the club where the incident occurred is to fill out an Executive Incident Report (on MAAC website).

- Obtain names, addresses, and phone #'s of all witnesses and their relationship to claimant, if any.

- Have **members** witnessing the incident fill out an Incident Witness Report (on MAAC website) with all details of what they saw.

- Complete the INCIDENT REPORT FORM on the MAAC website. It can be completed “on line” or can be “faxed” to MAAC Headquarters (fax #905-632-3304). **The office will confirm membership status of club/member(s) involved.**

- A \$500 deductible is payable to MAAC by the member/MAAC Club involved in the incident. MAAC Club portion is \$250 and member pays the other \$250. The MAAC Club is responsible for paying the entire \$500 to MAAC by cheque as quickly as possible and may be paid by credit card when faxing the drawing portion of the incident form to headquarters. Member/Club deductible payments are accepted by MAAC on a “without prejudice” basis pending completion of the investigation.

- **Once the incident has been reported to the Insurance Company, no further contact or discussions should be held with the claimant. Refer them to MAAC or the Adjuster only.** Our adjuster “Crawford & Co. (Canada) Inc.” will contact the modeller and the claimant(s).

- If litigation follows, contact the MAAC Head Office immediately for instructions and

- Advise the following means of service: Type of service – i.e. bailiff, registered mail, or regular mail and the **Date and Time** on which it was served.

Note: The above gives an outline of what to do when an incident occurs. All incidents should be reported whether a claim results or not. Only by examining what we do can we improve the safety of the hobby. We can only learn from our experiences so help others to learn and let us know what is happening out there.